

EMUGE

Spanntechnik

Jetzt NEU:

**KSN5/HD/Softsynchro®
Schneidbereich M30-M48**



KSN5/HD/Softsynchro®

Gewindeschneidfutter zum Synchron-Gewindeschneiden mit
Minimallängenausgleich und innerer Kühlschmierstoff-Zufuhr

Technische Merkmale:

IKZ	Innere Kühlschmierstoff-Zufuhr	p_{max} 50bar (700psi)	Kühlschmierstoff-Druck am Futtereintritt	↕ C ↕ T	Längenausgleich in Druck- und Zugrichtung	ER_(GB)	Werkzeugadaptionierung über Spannzangen
------------	-----------------------------------	---	---	------------	--	--------------------------	--

Kegel-Hohlschaft DIN 69893 A

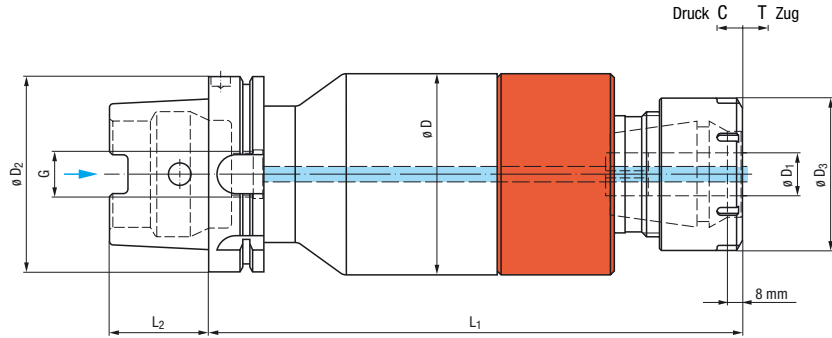

mit Bohrung für Datenträger DIN 69873

Typ		ø D ₁		ø D ₂	ø D	ø D ₃	L ₁ ER	L ₁ ER-GB	L ₂	G	C	T	Artikel-Nr.
KSN5HD/ Softsynchro	M30 - M48 (1 1/8" - 1 3/4")	22 - 36	ER 50 (GB)	HSK-A100	103	78	269	265,5	50	M24 x 1,5	2	2	F3155C06.1

Steilkegelschaft DIN 69871 AD/B

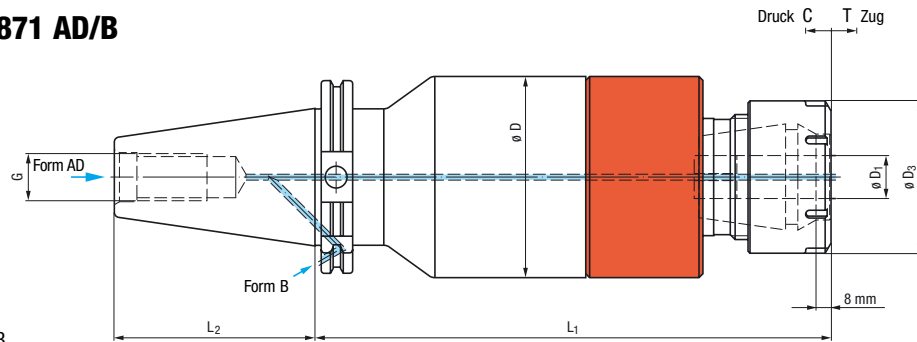

mit Bohrung für Datenträger DIN 69873

Type		ø D ₁		SK	ø D	ø D ₃	L ₁ ER	L ₁ ER-GB	L ₂	G	C	T	Artikel-Nr.
KSN5HD/ Softsynchro	M30 - M48 (1 1/8" - 1 3/4")	22 - 36	ER 50 (GB)	SK 50 AD	103	78	267,5	264	101,75	M24	2	2	F3155653.1
				SK 50 B	103	78	267,5	264	101,75	M24	2	2	F3155653.2

Steilkegelschaft ASME B5.50 UNC

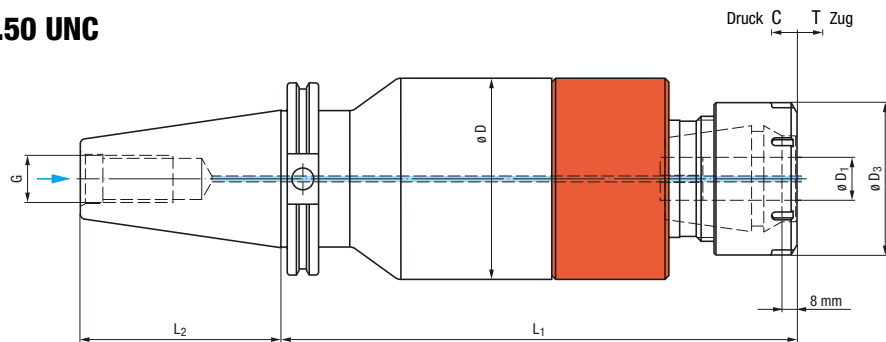

mit Bohrung für Datenträger DIN 69873

Type		ø D ₁		SK	ø D	ø D ₃	L ₁ ER	L ₁ ER-GB	L ₂	G	C	T	Artikel-Nr.
KSN5HD/ Softsynchro	M30 - M48 (1 1/8" - 1 3/4")	22 - 36	ER 50 (GB)	SK 50	103	78	267,5	264	101,6	1" - 8	2	2	F3155783.1.16